

# DC Electrical System on SAY GOODBYE 1982 41 Defever Trawler

## Battery Selector Switch (back view)

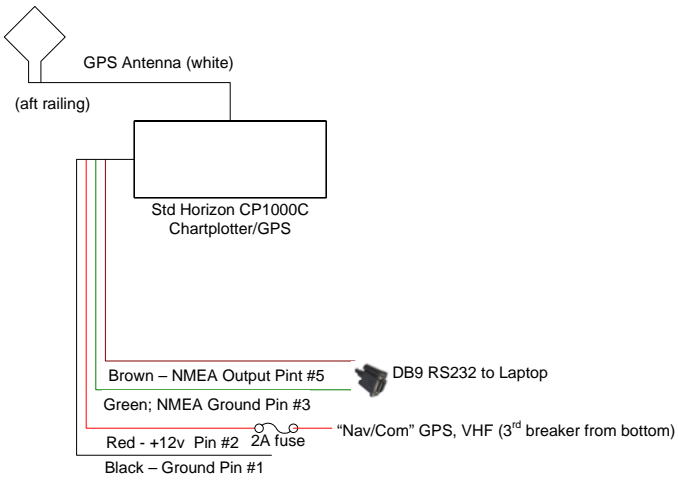
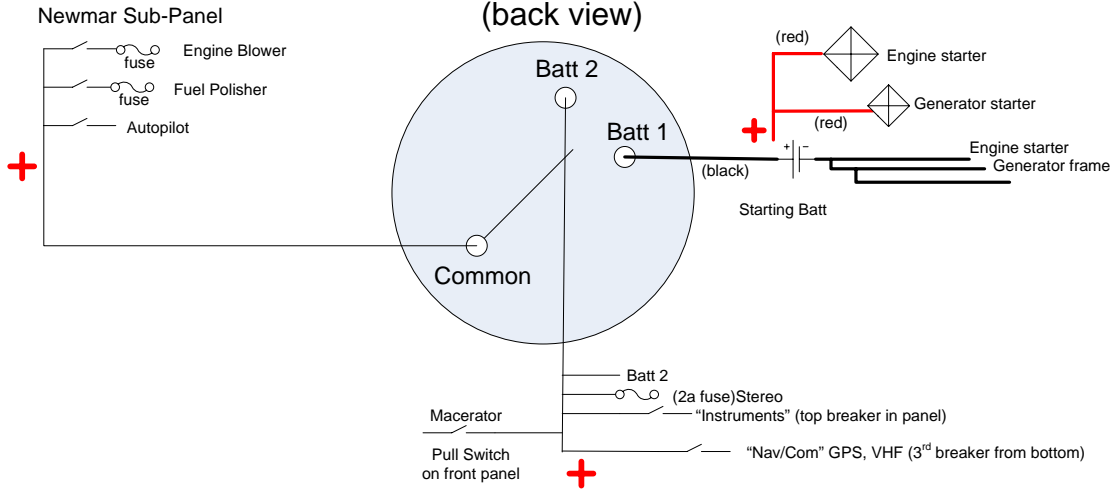

Black - Ground Pin #1  
 Red - +12v Pin #2  
 Green; NMEA Ground Pin #3  
 Brown - NMEA Output Pint #5